

Bowser (Tank Truck) Loading Application

Accurate P. D. Flow Meters for Bowser Loading
Fuel, Ethanol, Spirits, Solvents & other liquids...

Salient Features:

- *High Accuracy & Repeatability of 0.02%*
- *Approved by Weights & Measures, Legal Metrology*
- *Top loading and Bottom loading configurations available*
- *Skid or Gantry based complete solutions available*
- *Printing & Computer interface integration possible*
- *Reliable, hassle-free maintenance and fast service*

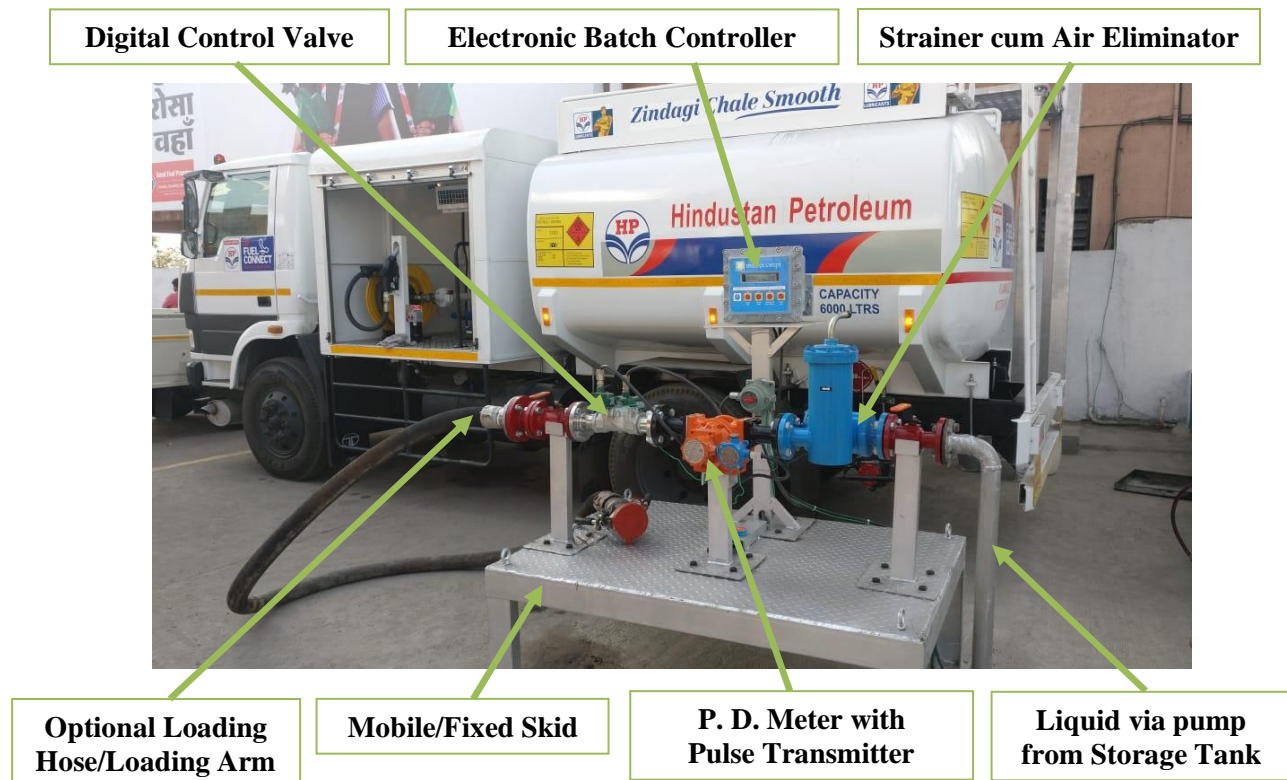

Pic. 1: P. D. Flowmeter in Bottom Loading operation at a location



Corporate Office & Operations:

Plot No. PAP-A-8/6, "A" Block, Phase IV, MIDC Chakan, Opp Mahindra Vehicle,
Dist. Pune - 410 501, Maharashtra.
Tel : +91 9168179461/ 9168176683
E-mail : ho@vermonttechnologies.co.in
Website : www.vermonttechnologies.co.in

Truck Meter (Diesel Bowser/ Refueller/ Mobile Dispenser)

1. P. D. Flowmeter
2. Pulse Transmitter
3. Digital Control Valve
4. Strainer cum Air Eliminator
5. Ball Valve
6. Pressure Gauge
7. Flow Totaliser
8. Display Mounting Stand
9. Loading Arm
10. Gantry Structure

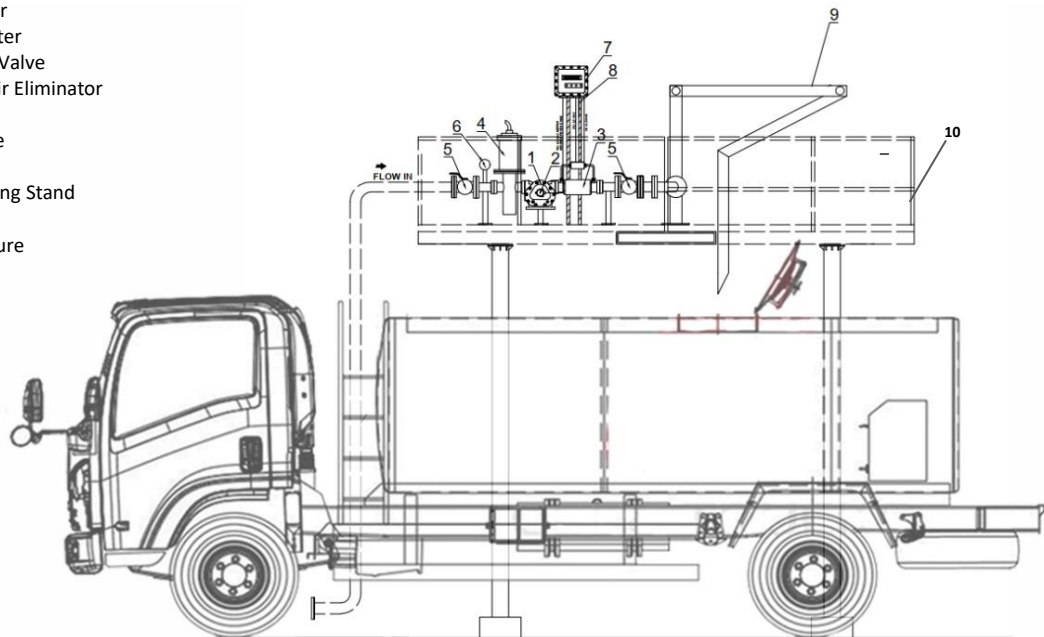

Pic. 2: Typical Top Loading Arrangement

Note: - Top loading & Bottom loading options as per requirement

1. Top loading – Gantry mounted System same as per schematic above.
2. Bottom loading – Skid mounted System with Bottom loading arm with API Coupler or Hose.



Corporate Office & Operations:

Plot No. PAP-A-8/6, "A" Block, Phase IV, MIDC Chakan, Opp Mahindra Vehicle,
Dist. Pune - 410 501, Maharashtra.
Tel : +91 9168179461/ 9168176683
E-mail : ho@vermonttechnologies.co.in
Website : www.vermonttechnologies.co.in